

**CUT 20**  
**CUT 30**

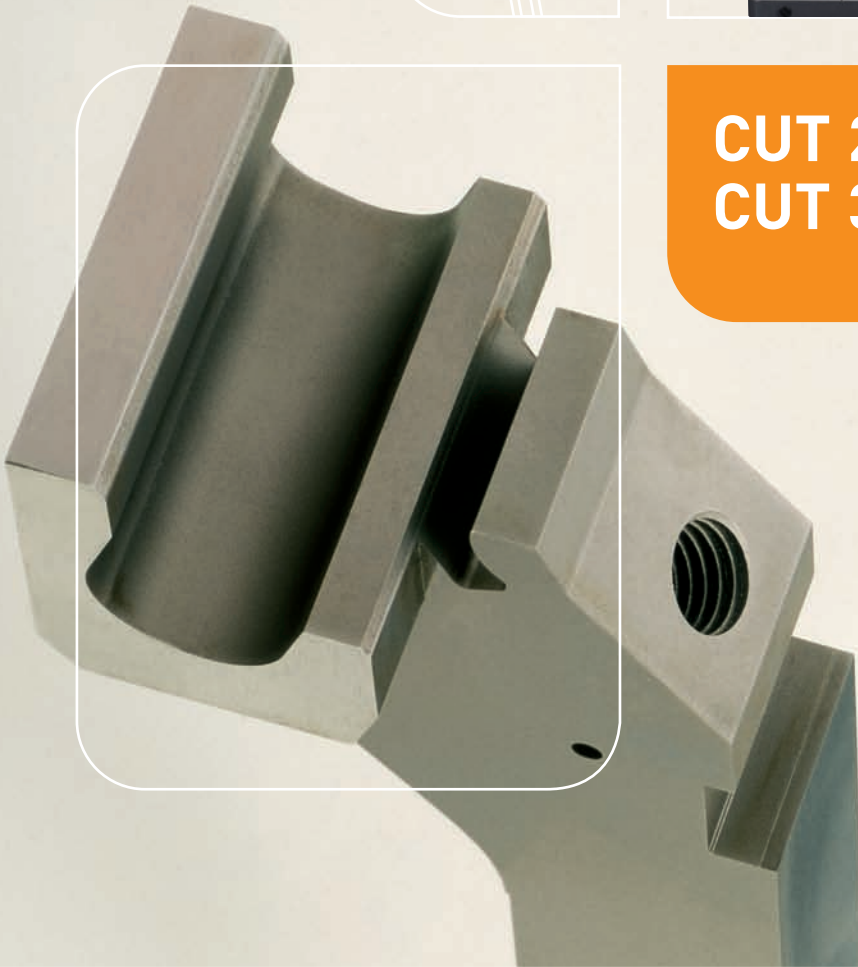



## CUT 20

Ease of use combined  
with outstanding performances.

# Contents

Highlights	4
Mechanical structure	6
Wire circuit	8
Generator and technology	12
Control unit	16



## CUT 30

Good accessibility for large work pieces dimensions combined with outstanding performances

## Highlights

The solution  
for standard parts and  
general engineering

- Outstanding  
price/perfor-  
mance ratio

- Ready to perform

- Simple to use  
graphics user  
interface

- Low operating  
costs

- High cutting  
rates



### Outstanding price/performance ratio

The CUT 20/30, an EDM wire-cutting unit, is a very interesting machine offering outstanding features and excellent cutting performances. Equipped with joint technology from GF AgieCharmilles it positions itself as the ultimate in price/performance WEDM machine in the market place. It handles wire diameters from 0.15 to 0.30 mm (0,0059 to 0.0118 in) with ease and is highly flexible to satisfy most of the requirements in the field of general engineering and standard stamping.

### Ready to perform

The practical structural layout yields the shortest possible installation time, and the customer can be productive within a few hours after delivery. The design takes in account good accessibility of the maintenance points, such as the filter cartridges, the wire container, upper and lower heads. This shortens down-time to the minimum and ensures safe, easy maintenance and operation. Equally, the work tank design ensures a comfortable accessibility.

### Simple to use graphics user interface

The simple and functional user interface facilitates direct and intuitive dialogue. The input of data takes place in a structured manner with pictures and symbols guiding even inexperienced operators to fast effective results. The Windows XP operating system allows direct Import/export of ISO files, through:

- USB memory key
- LAN network

and checking by a 3D graphic mode.

Short return of investment



More competitiveness



### Operating costs

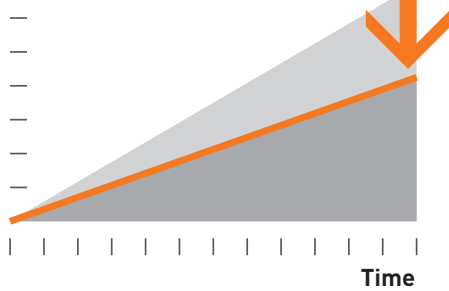

### Low operating costs

- Low energy consumption of its compact and modern generator
- Long life time of the wear parts

### High cutting rates

The GF AgieCharmilles generator, equipped with the latest technology, assures outstanding performances and highly competitive results.

For example:

- The new "Speed" technology package, allow in 2 to 4 cuts to reach competitive results in terms of precision, time and surface roughness.
- Its operating costs are minimised thanks to its sophisticated technology when brass wires are employed.

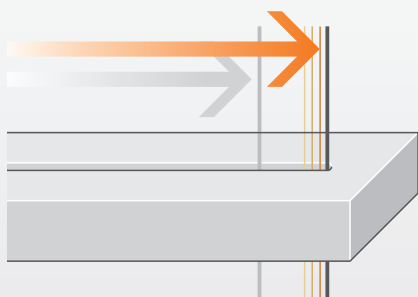
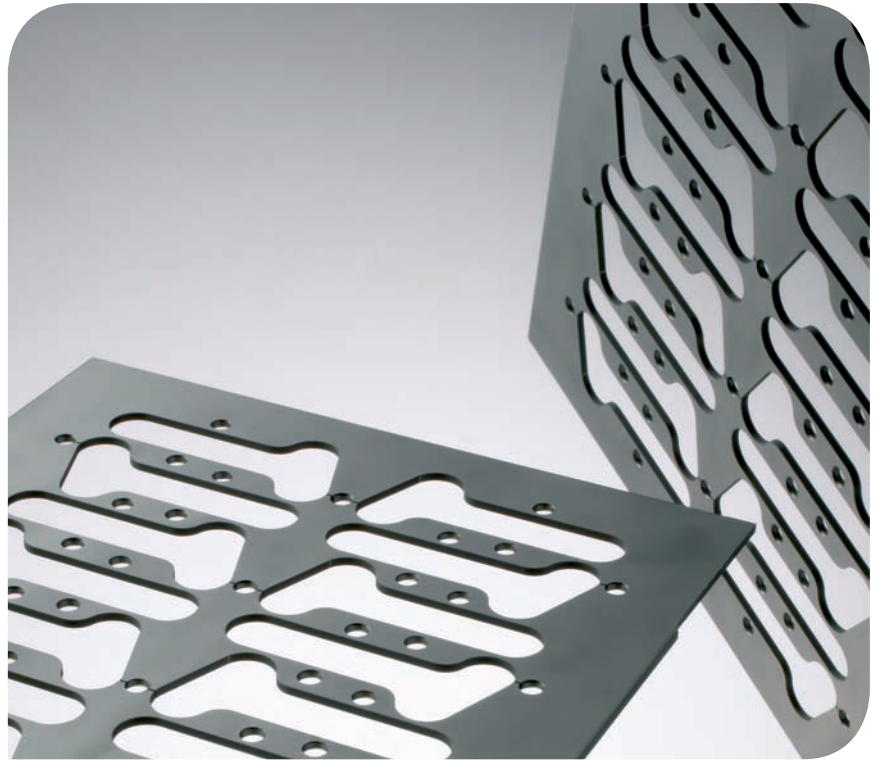



## Mechanical structure

Solid structure for a reliable and durable operation



- T-shaped base frame
- Machining of large work pieces
- Universal Clamping frame
- Thickness 45 mm for high solidity

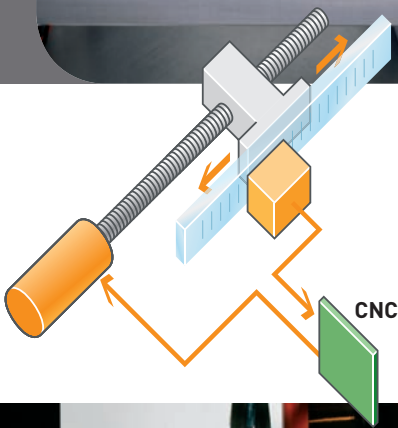

### Glass Scales for high accuracy

To obtain durable accuracy, direct measurement of positions by linear scales is used. This system enables the actual movement of the slide to be checked directly. It eliminates all the classic errors that arise from the screw, such as backlash on reversal, expansion or wear. Accuracy does not vary over time and no subsequent calibrating is required.

### Machining of large work pieces

Designed to maximise its class leading work area size and travels. Along with its advanced AWT greater productivity is achieved, as extended running during lights out is a reality. If large work pieces are needed to be machined the excellent accessibility allows a hassle free loading and

unloading of work pieces of 1000 kg (2204 lb) in weight and maximum size of (L x W x H) 1050 x 800 x 350 mm (41.30 x 31.50 x 13.75 in).

### Working zone

Easy accessibility to the working area and to the work clamping frame makes the mounting of work pieces a rapid operation. The clamping frame is manufactured out of hardened steel and with a thickness of 45 mm and is extraordinarily rigid.

Maximum submerged cutting:

250 mm (9.84 in) CUT 20  
350 mm (13.78 in) CUT 30.

Intermediate water level for thermal stability.



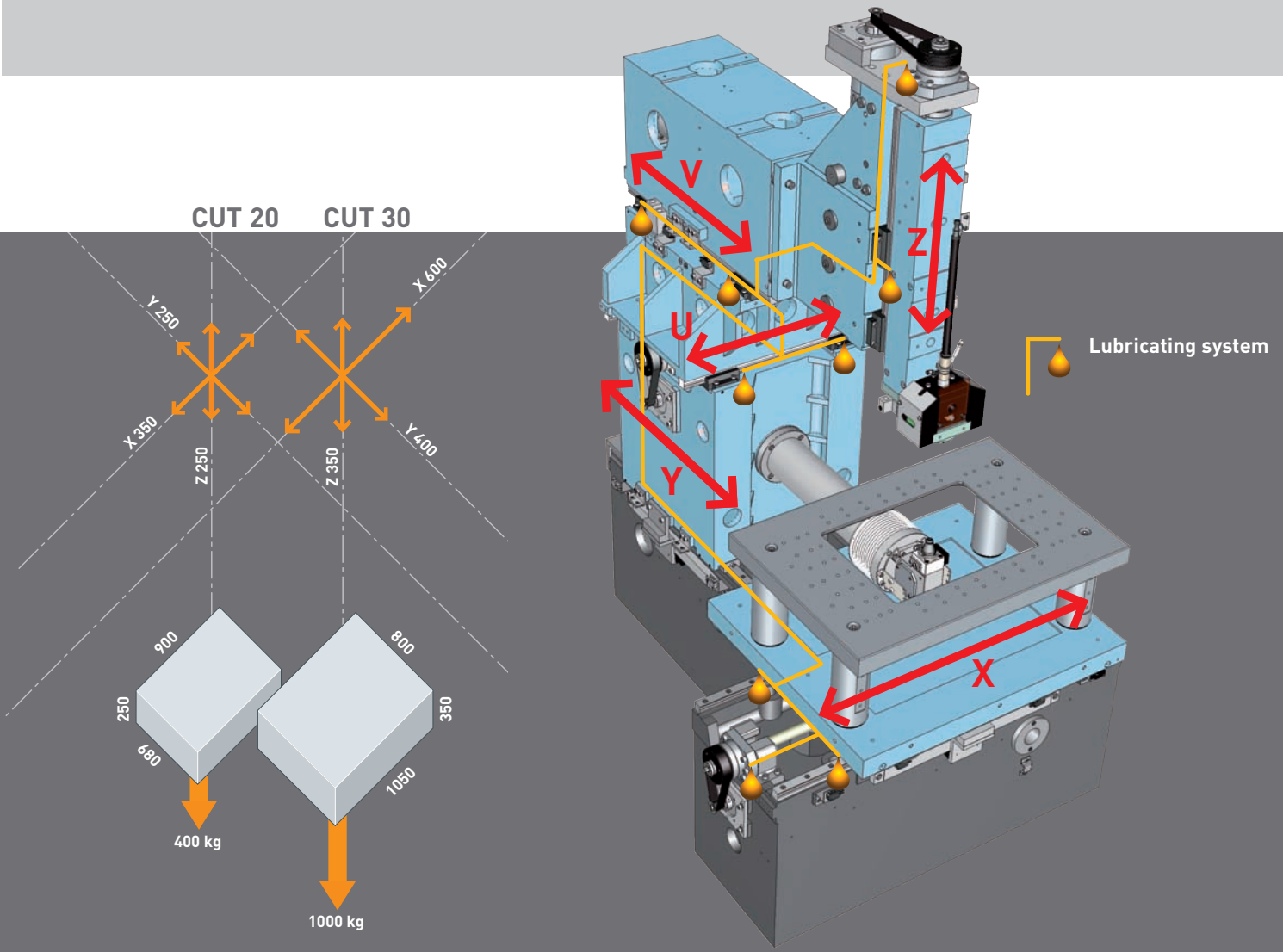

### Base Structure

The T-shaped base frame permits the loading of larger and heavy work pieces. The compact and rigid machine structure guarantees good positioning accuracy and highly repeatable results.

### Lubricating system

The unique design of the centralized lubrication system minimises the machining down time. It lubricates the guides and sliding blocks as well as the ball-screws, simplifying the maintenance tasks.



### Long running hours

The CUT 20/30 disposes of:

- Deionising bottle with a volume of 20 l (5.3 gal)
- 2 filter cartridges of 450 mm (17.71in) height x 340 mm (13.38 in) diameter each limiting operator intervention time.

### Chiller included in standard configuration

A compact chiller is delivered with the standard equipment of the machine. It guarantees optimal machining conditions by maintaining the overall dielectric (Water) temperature.



## Wire circuit

Modern reliable wire circuit,  
GF AgieCharmilles design

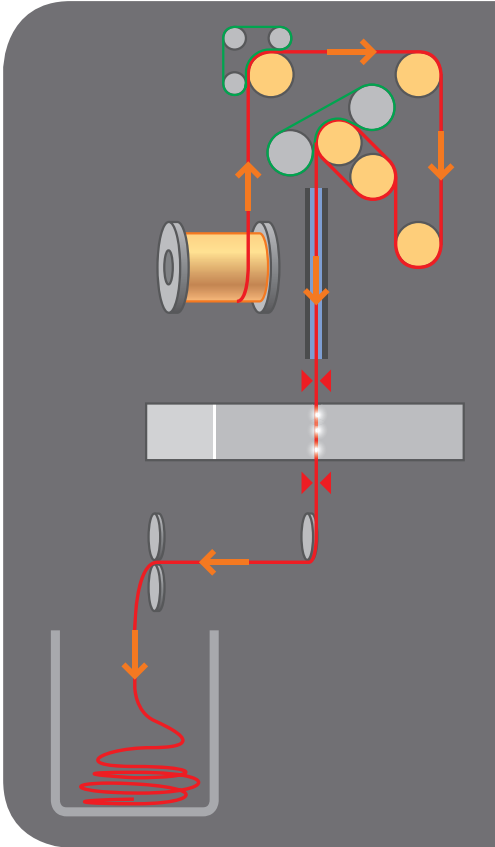

### Wire system

The wire system has been designed by GF AgieCharmilles and is an optimized version from tried and tested solutions. The wire tension is monitored by an electromagnetic break, CNC programmable. The wire spool storage has been designed to be easily accessible so that the operator can carry out a rapid change of spools.

The CUT 20/30, handles the following standard wire diameters:

- 0.15 mm (0.0059 in)
- 0.20 mm (0.0079 in)
- 0.25 mm (0.0098 in)
- 0.30 mm (0.0118 in)

### Simple wire circuit

The concept of wire circuit is composed by very few components and consumable parts. They are: wire guides, wire contacts and pinch rollers. Besides the low running costs, the advantages of this system are a high reliability during threading, rethreading and functioning.

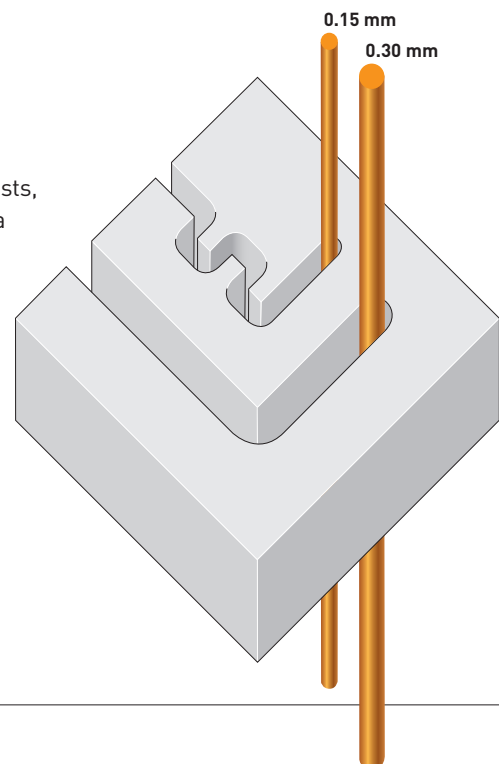



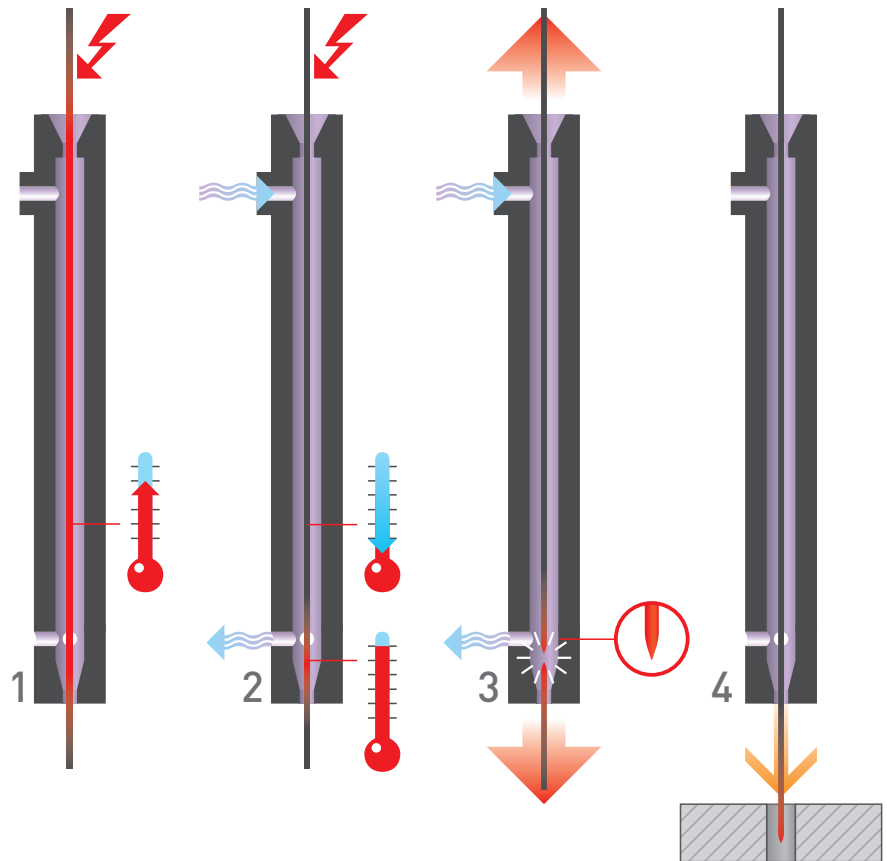
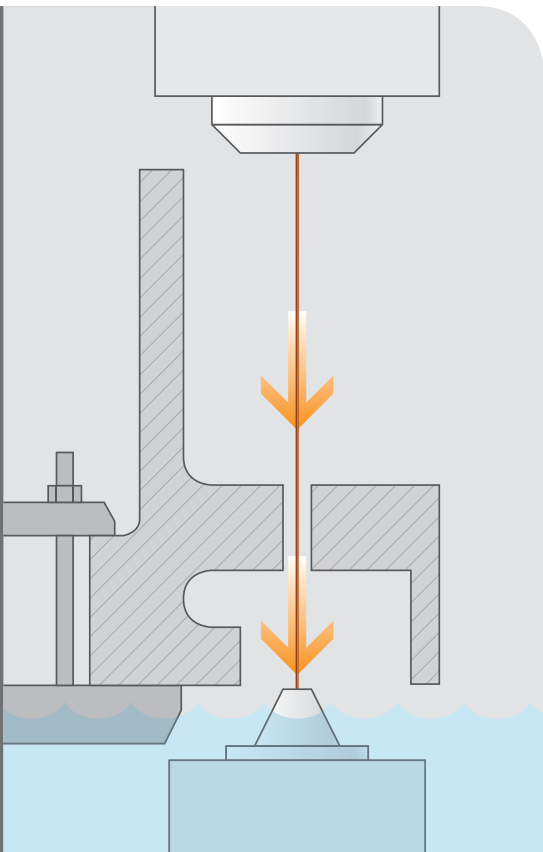

### Automatic Threading and rethreading

As standard and to ensure unattended running hours, the equipment includes an automatic wire-threading and rethreading system.

### Thermo cut system for all types of wire

The automatic threading is rapid and reliable whatever the type of wire used: hard or soft brass, coated or not. The key of success is preparing the wire properly before threading.

#### 1. Wire heating

The wire is heated between the break and the upper head.

#### 2. Wire cooling

An air jet cools down the wire and in the mean time is stretched in order to reduce its diameter.

#### 3. Wire cut

The wire is annealed and stretched over a certain length. The thermal breakage leaves no burr and tapers the extremity.

#### 4. New threading

The newly prepared wire facilitates its path through the guides and parts.



Achieve more...

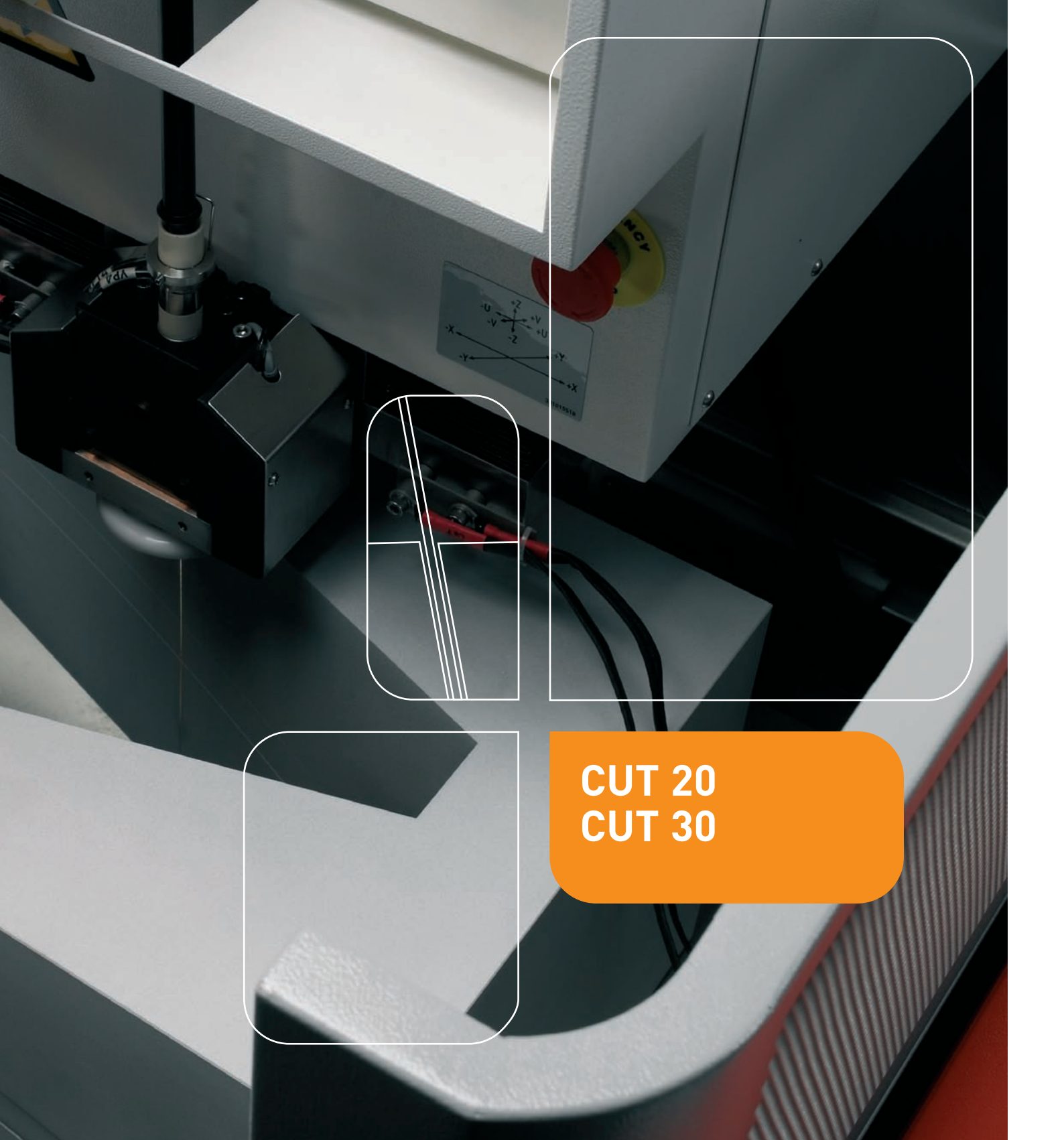

**CUT 20**  
**CUT 30**



## Generator and technology

GF AgieCharmilles,  
Swiss made generator and complete technology

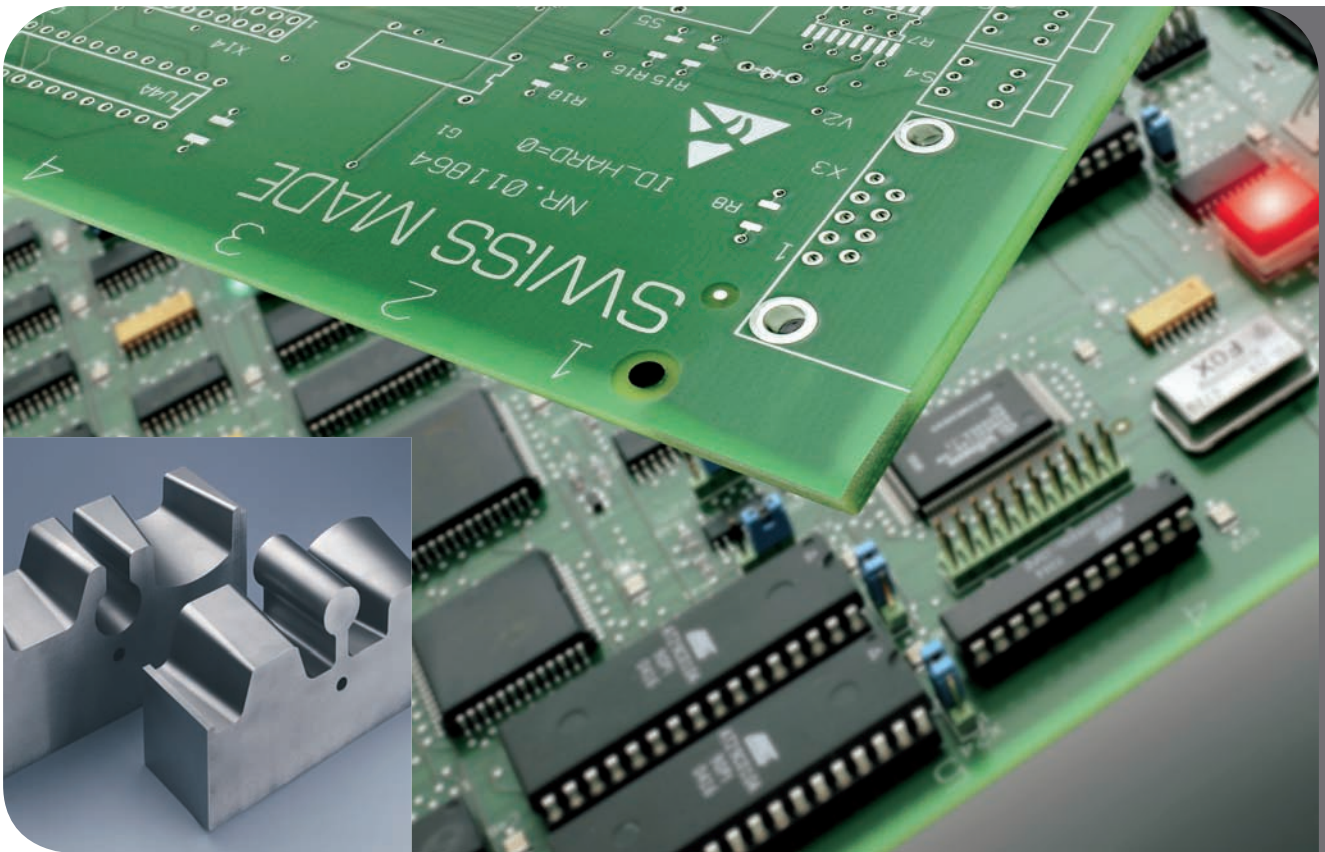

### Powerful Generator

It integrates a SF (Fine Surface) module with which a surface roughness of less than  $Ra\ 0.25\ \mu m$  ( $0.01\ \mu in$ ) can be achieved. The generator, completely anti-electrolysis, assures an homogenous and perfect surface finish. Along with the performance, the up-to-date electronics used in manufacturing ensure that the cost of ownership is the lowest possible.

### Highest level of generator performance

The thoroughly tested generator of the CUT 20/30 with reliable electronics, is based on state-of-the-art technology developed by GF AgieCharmilles. Extremely high removal rates are possible with cheap brass wires, adding low hourly running cost to its unique features.

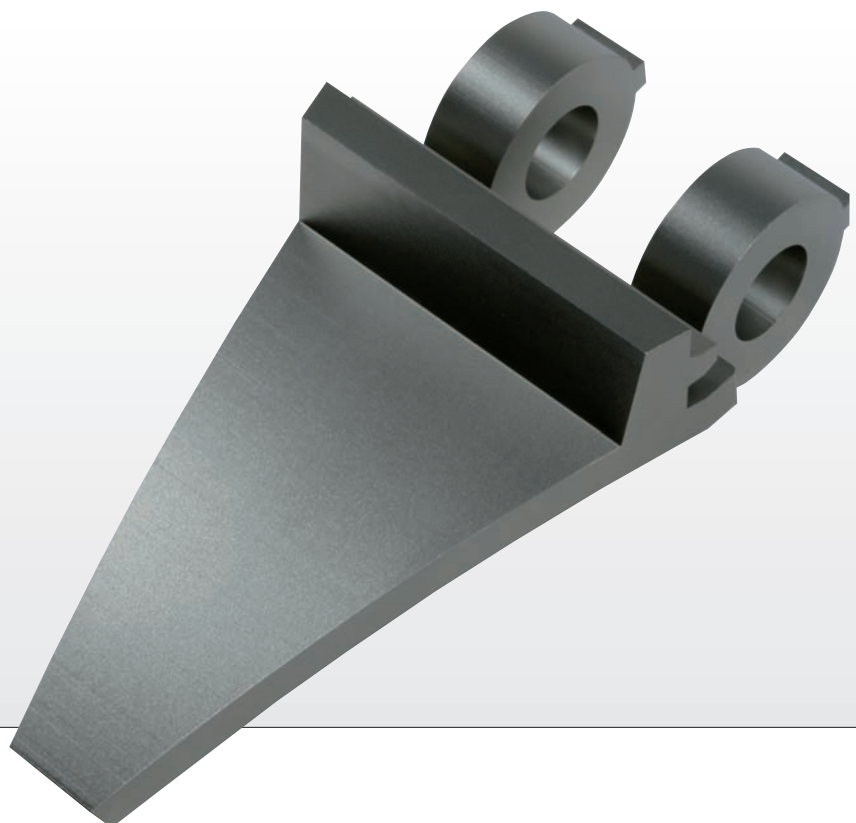



### GF AgieCharmilles Generator

- Highest level of generator performance
- High speed generator
- Application oriented technologies
- Complete technology range using wires from  $\varnothing$  0.15 mm (0.0059 in) up to  $\varnothing$  0.30 mm (0.0118 in)

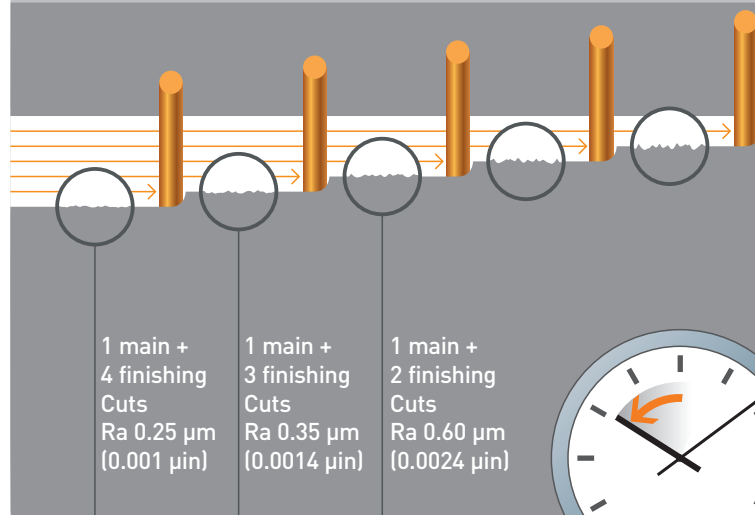

### Technologies

Thanks to the FPGA technology (Field Programmable Gate Arrays - a logic device programmable instantaneously) and the completely digital process monitoring, servo response demonstrates a degree of flexibility that can only be achieved with a system designed specifically for EDM. The technology database package covers all requirements in a workshop. These technologies work with a variety of wires and encompass material ranging from steel to hard metals. It also has the flexibility to produce results from rapid cuts to precision finishing cuts.

### Speed technologies

The CUT 20/30 has on board technologies that allow a unique speed cut. This technology optimises main, 2<sup>nd</sup> and 3<sup>rd</sup> finishing cuts, to attain the most common values of surface roughness, like Ra 0.60  $\mu\text{m}$  (0.0024  $\mu\text{in}$ ) and Ra 0.35  $\mu\text{m}$  (0.0014  $\mu\text{in}$ ) to be achieved in a minimum of time. This high speed technology makes the CUT 20/30 a very powerful competitive production unit.

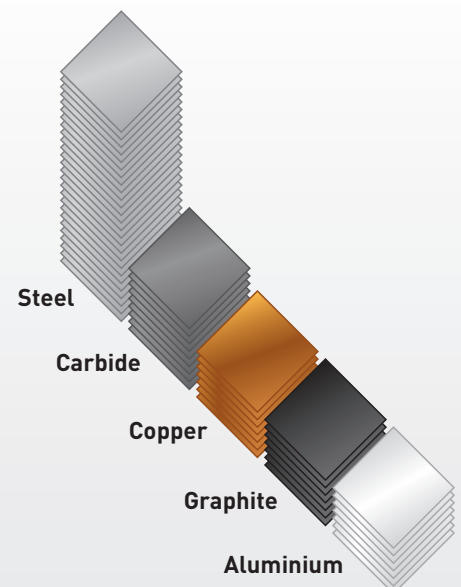
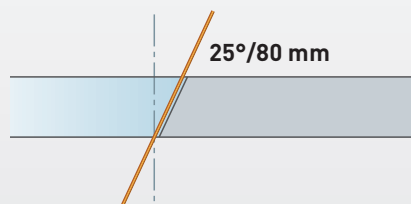



## Generator and technology

GF AgieCharmilles,  
Swiss made generator and complete technology

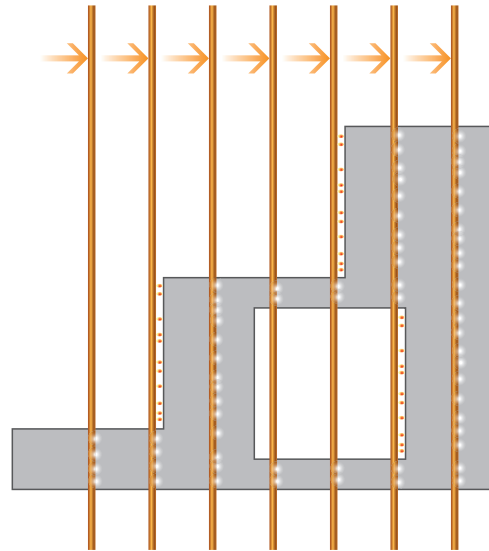
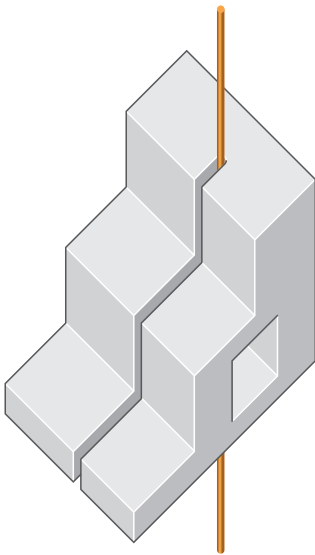

### Strategy for stepped work pieces

The Generator can manage and erode stepped work pieces. This function detects the difference of the material thickness in order to adapt automatically the power to the changing conditions.

### Corner strategy

To ensure accuracy of:

- sharp angles
- small radii

the corner strategies adjust automatically the machining parameters during changes of direction. Even on the smallest details, high geometrical accuracy is obtained.

### Without corner strategy

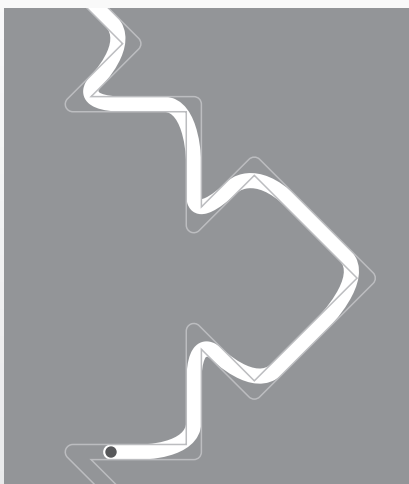

### With corner strategy



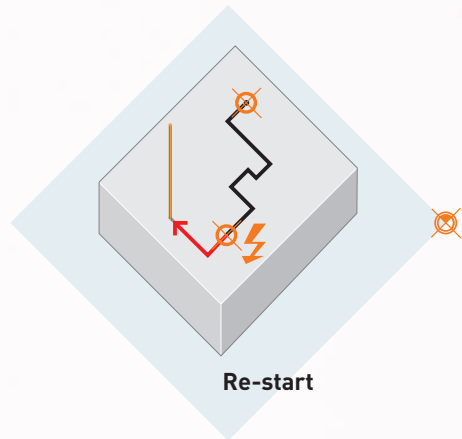
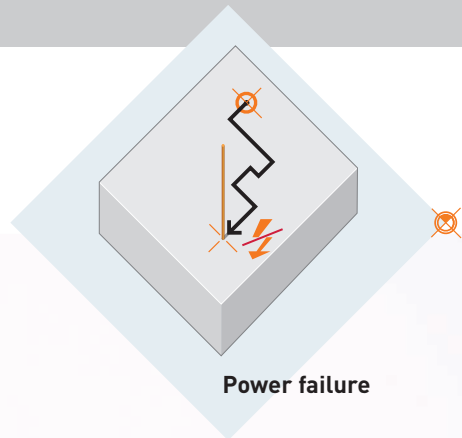

**Power failure recovery**

In case of power failure, the point and the job name are memorised, allowing a direct re-start of the job after power restoring.

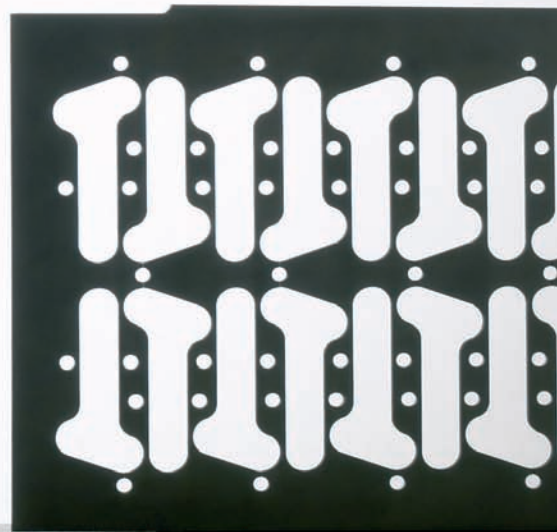

## Control unit

Efficiency through Simplicity

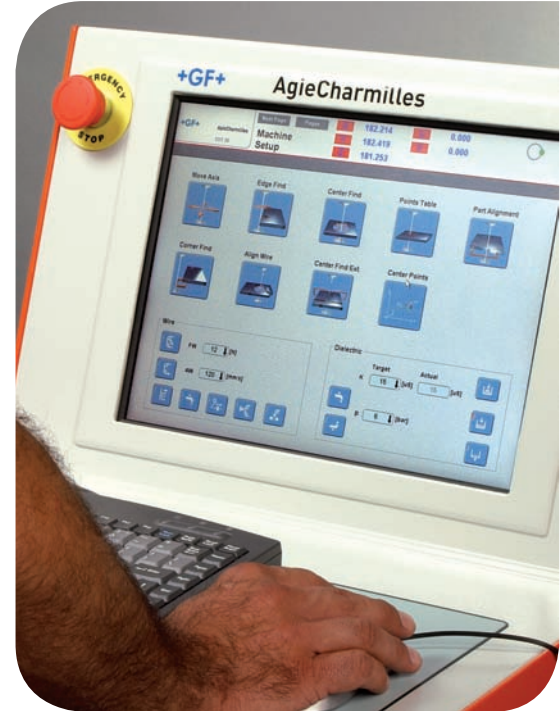
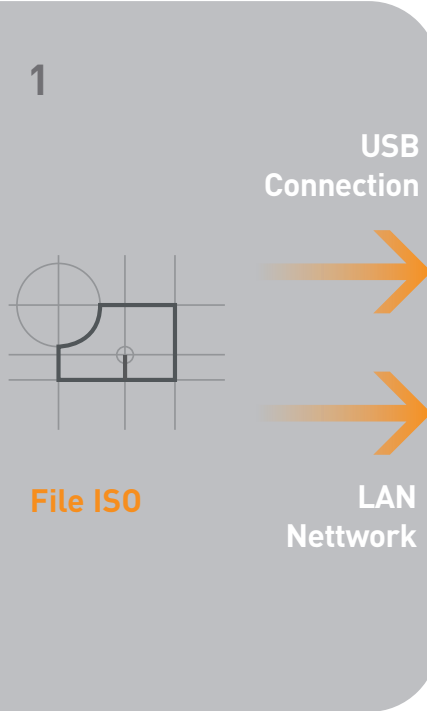
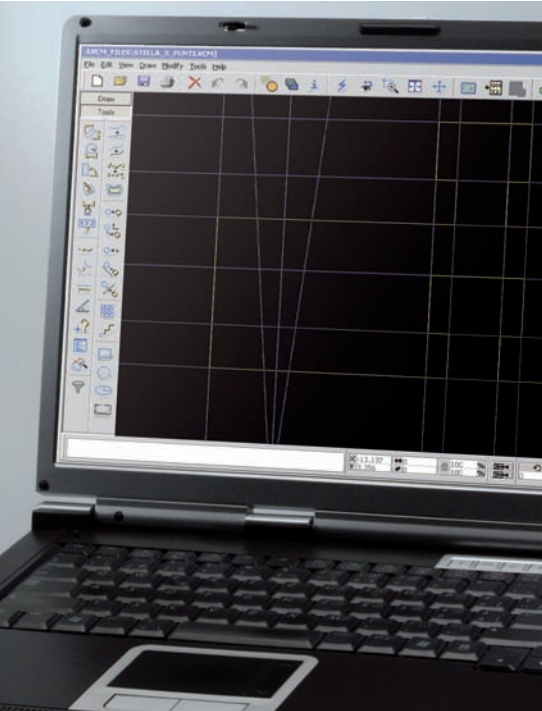

### Control unit

The graphics user interface is based on the Windows XP operating system and allows real time control of the EDM process. The system works with descriptive picture symbols and conversational screen pages following one after another in a logical way. This allows even new users to understand the WEDM principle quickly and means time to production is very short. The unique programming system also gives to the users a large degree of flexibility in a production environment, allowing a simple and fast setup and any hours of labour free running of the machine.

### 1 Job preparation

Most CAD/CAM programs worldwide are compatible with the CUT 20/30 giving the operator a large level of integration.

### 2 Measuring cycles

The intuitive, easy-to-use measuring functions allow the operator to quickly determine work piece references.

### 3 Technology definition

The choice of the right technology is easily done by the operator. The technology database selects the appropriate setting in according to the characteristics of the application.

- Work piece material
- Work piece height
- Required roughness
- Wire type

### 4 EDM process

The EDM process is monitored by the operator in real time; by means of the "EDM Process" IHM screens he can check and optimise all the important technology parameters.



**2**

Work zone preparation, measuring cycles

- Edge find
- Corner find
- Center find
- Part alignment
- Center find Ext

Move Axis    Edge Find    Center Find    Points Table    Part Alignment

Corner Find    Align Wire    Center Find Ext.    Center Points

Wire

FW 12 [N]

AW 120 [mm/s]

Dielectric

Target    Actual

K 15 [uS] [uS]

P 6 [Bar]

**3**

Workpiece    Wire

H

Ra

$\emptyset$

Technology definition

TECCUT Dialogue

TEC C:\Actspark\PublicDriver\NewTECFile.TEC

Wire Type Brass

Wire Diameter 0.25

Workpiece Material St

Workpiece Height 30.000

Required Ra 0.60

Required Taper 0

Favour Speed

Cancel    <<Back    Next>>    Finish

**4**

Live erosion monitoring

File Management    ISO Editor    TEC Editor    Graph Check

C:\User\Progett\EMEI\Wire\Pocket part ISO Pocket Part CylISO

View Mode

- Plane
- Frame
- Solid

View Range

- Workpiece
- Tank

Legend

- HS NS1 NS2
- NS3 NS4 NS5
- Others

Settings



# About GF AgieCharmilles

## **Milling** High-Speed and High-Performance Milling Centers

In terms of cutting speed, HSM centers are 10 times faster than conventional milling machines. Greater accuracy and a better surface finish are also achieved. This means that even tempered materials can be machined to a condition where they are largely ready to use. One essential advantage of HSM is that with systematic integration, the process chain can be significantly shortened. HSM has developed alongside EDM into one of the key technologies in mold and tool making.

## **EDM** Electric Discharge Machines

EDM can be used to machine conductive materials of any hardness (for example steel or titanium) to an accuracy of up to one thousandth of a millimeter with no mechanical action. By virtue of these properties, EDM is one of the key technologies in mold and tool making. There are two distinct processes – wire-cutting EDM and die-sinking EDM.

## **Automation** Tooling, Automation, Software

Tooling for fixing workpieces and tools; automation systems and system software for configuring machine tools and recording and exchanging data with the various system components.

## **Spindle** HSM Spindle Technology

Development, production and sale of the motor spindles that form the core components of modern HSM centers. The spindles rotate at speeds between 10 000 and 60 000 rpm.

## **Service** Services and Consumables

Service, maintenance, spare parts and consumables for EDM, milling and HSM systems as well as for other machine tools; consumables include filters, wire, graphite, copper electrodes and special resin.





**Contact**

[www.gfac.com](http://www.gfac.com)

**+GF+**

**AgieCharmilles**

**Achieve more...**

# Technical Data

## CUT 20/30

		CUT 20	CUT 30
<b>Machine</b>			
Machine dimensions (L x W x H)	mm in	2500 x 2500 x 2200 98.5 x 98.5 x 86.6	3100 x 2800 x 2325 122 x 111.2 x 91.5
Machine floor space	mm in	3500 x 3500 137.8 x 137.8	4000 x 4000 157.5 x 157.5
Machine weight (Without dielectric)	Kg lb	3000 6613	5000 11023
<b>Work zone</b>			
Max. inside dimensions (L x W x H)	mm in	1050 x 765 x 560 41.3 x 30.1 x 22	1260 x 945 x 675 49.60 x 37.20 x 26.57
Maximum workpiece size	mm in	900 x 680 x 250 33.43 x 26.77 x 9.84	1050 x 800 x 350 41.30 x 31.50 x 13.75
Maximum workpiece weight	kg lb	400 882	1000 2204
Table size	mm in	700 x 480 27.55 x 18.89	950 x 630 37.4 x 24.80
Angle of tank door	°	180°	180°
Distance between table surface and floor	mm in	1050 41.33	1060 41.70
<b>Axis</b>			
Travel X/Y/Z	mm in	350 x 250 x 250 13.78 x 9.84 x 9.84	600 x 400 x 350 23.60 x 15.70 x 13.75
Travel U/V	mm in	± 45 ± 1.77	± 50 1.95
Measurement device		Glass scales (XY) / encoder (UVZ)	Glass scales (XY) / encoder (UVZ)
Minimum resolution	µm µin	0.1 4	0.1 4
<b>Taper cutting</b>			
Maximum taper angle	Angle/Height	± 25°/ 80 ± 25°/3.5	± 25°/ 80 ± 25°/3.5
<b>Wire drive system</b>			
Wire guide diameter	Ø mm in	0.15, 0.20, 0.25, 0.30 0.0059, 0.0079, 0.0098, 0.0118	0.15, 0.20, 0.25, 0.30 0.0059, 0.0079, 0.0098, 0.0118
Spool weight	kg lb	5; 8 11; 16.6	5; 8 11; 16.6
Wire tension	N	3 ~ 30	3 ~ 30
Wire speed	mm/s in/s	30 ~ 330 1.18~13	30 ~ 330 1.18~13
Wire threading		Automatic (standard)	Automatic (standard)
<b>Dielectric unit</b>			
Capacity of clean water tank	L gal	200 53	230 60.75
Capacity of dirty water tank	L gal	600 158.5	970 256
Filter cartridge		2	2
Filter cartridge (Height/diameter)	mm in	450 x Ø 340 17.71 x Ø 13.38	450 x Ø 340 17.71 x Ø 13.38
Capacity of deionizing bottle	L gal	20 5.3	20 5.3
<b>Generator</b>			
Maximum current	A	35	35
Best roughness Ra	µm	< 0.25 < 0.01	< 0.25 < 0.01

**CNC**

Control system		Pentium Intel	Pentium Intel
Hard disc	GB	" 40	" 40
Display		15" LCD	15" LCD
Operating system		Windows	Windows
Controlled axes		5, among which 4 simultaneous	5, among which 4 simultaneous
Port		USB, MDI, LAN port	USB, MDI, LAN port
Power failure protection function		Yes	Yes
3D/2D graph check/scale/move function		Yes	Yes

**Power supply**

Standard power supply	V	3 x 380 / 3 x 400	3 x 380 / 3 x 400
Main frequency	Hz	50 or 60	50 or 60
Permissible fluctuation		±10%	±10%
Power supply consumption	kVA	9	9
Full load current	A	13.5	13.5

**Air supply for wire threading**

Air pressure	bar	6 ~ 9	6 ~ 9
Diameter of pipe	mm	Ø 6	Ø 6

**General Data**

For guaranteed accuracy	C	20° ± 1°	20° ± 1°
For operation of the equipment	C	15° ~ 30°	15° ~ 30°
Permissible relative humidity		40% ~ 80%	40% ~ 80%

**Chiller specifications (Included in standard configuration)**

Dimension:	450 x 550 x 1040 mm	17.71 x 19.68 x 40.95 in
Cooling Capacity:	5 kW	
Power Supply:	3 x 400 V 50/60 Hz	
Rated Power:	2.5 kW	
Rated Current:	7 A	
Controlled Temperature Range:	15~50° C, Control Accuracy +/- 1° C	
Minimum Flow Rate:	30 l/min. 7.92 gal/min.	
Ambient Temperature:	10~45° C, auto stop if temperature > 48° C	

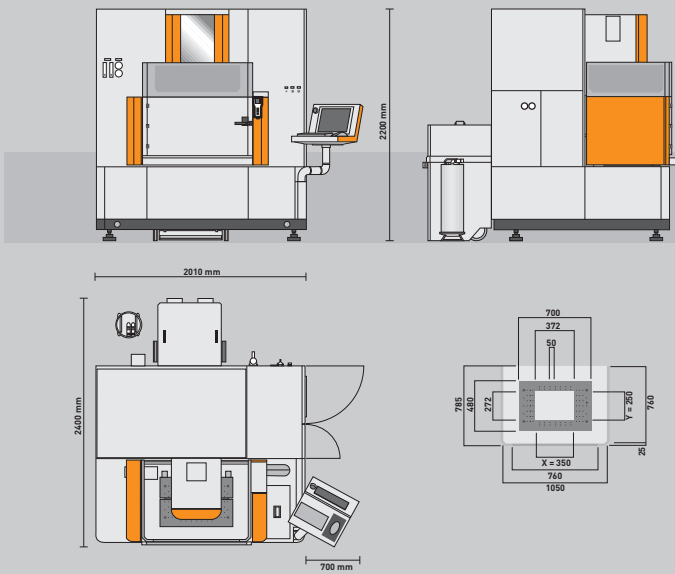

CUT 20

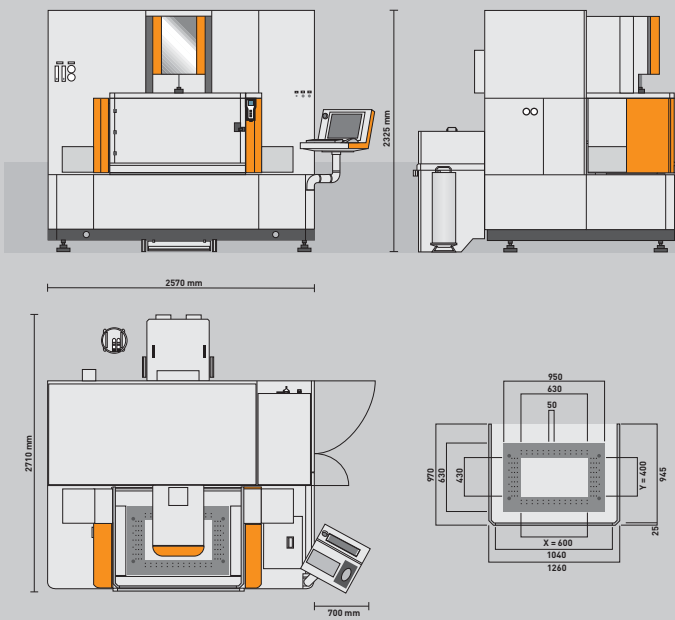

CUT 30



